

ITEM: 1

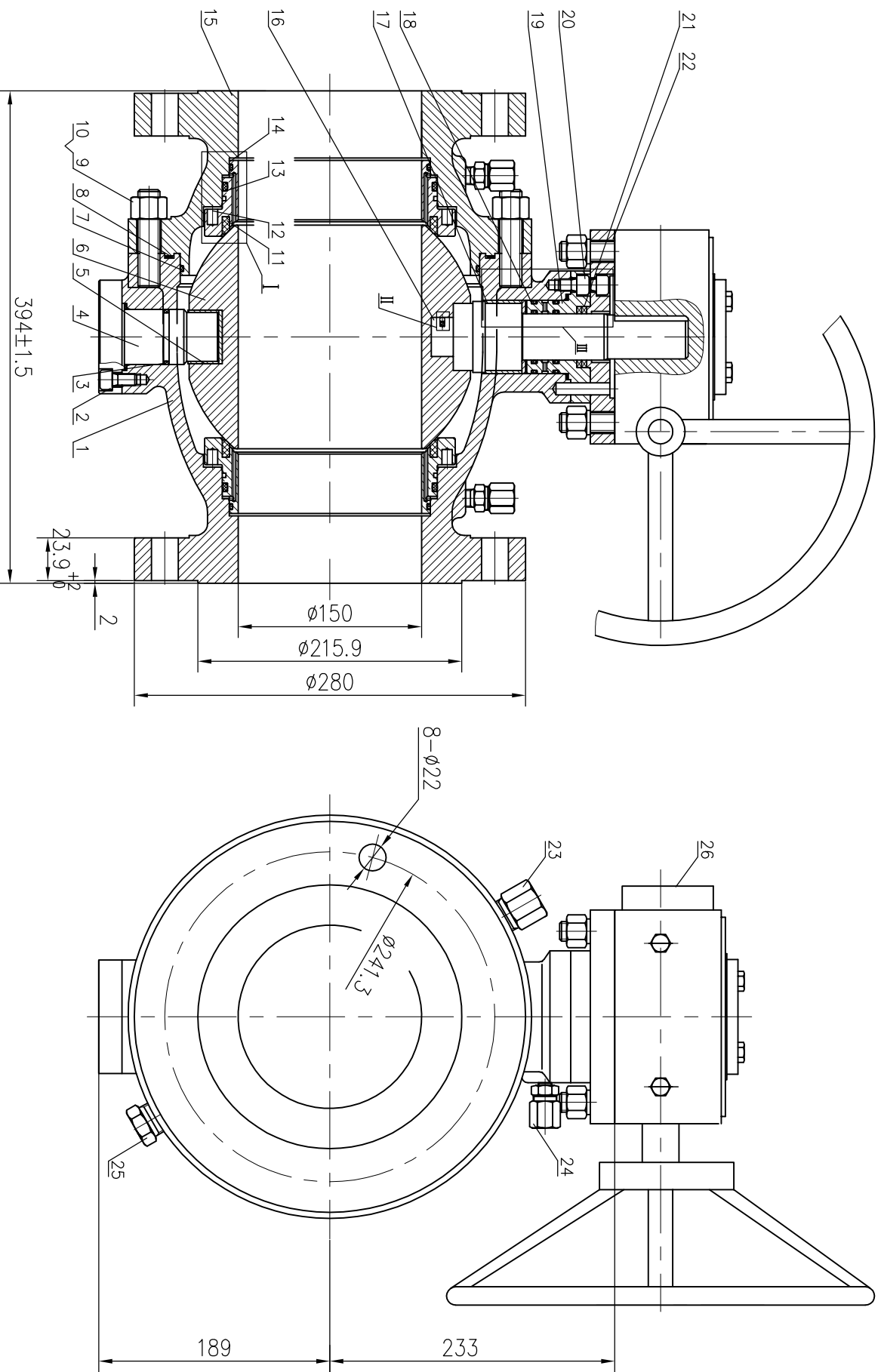

| NO. | PART NAME | MATERIAL | NOTE |
|-----|-----------------|----------------------|------|
| 1 | BODY | ASTM A216 WCB | |
| 2 | SCREW | ASTM A193 B7 | |
| 3 | O-RING | VITON | |
| 4 | TRUNNION | ASTM A105+ENP | |
| 5 | BUSHING | SS+PTFE | |
| 6 | BALL | ASTM A182 F316 | |
| 7 | O-RING | VITON | |
| 8 | GASKET | SS+FLEXIBLE GRAPHITE | |
| 9 | BOLT | ASTM A193 B7 | |
| 10 | NUT | ASTM A194 2H | |
| 11 | SEAT INSERT | RPTE | |
| 12 | SEAT SPRING | INCONEL X750 | |
| 13 | O-RING | VITON | |
| 14 | SEAT RING | ASTM A182 F316 | |
| 15 | CLOSURE | ASTM A216 WCB | |
| 16 | STEM | ASTM A182 F316 | |
| 17 | BUSHING | SS+PTFE | |
| 18 | O-RING | VITON | |
| 19 | STUFFING BOX | ASTM A105+ENP | |
| 20 | SCREW | ASTM A193 B7 | |
| 21 | PACKING | FLEXIBLE GRAPHITE | |
| 22 | MOUNTING FLANGE | ASTM A105 | |
| 23 | VENT VALVE | SS304 | |
| 24 | GREASE FITTING | SS304 | |
| 25 | DRAIN PLUG | SS304 | |
| 26 | GEAR | ASSEMBLY | |
| 27 | | | |
| 28 | | | |
| 29 | | | |
| 30 | | | |

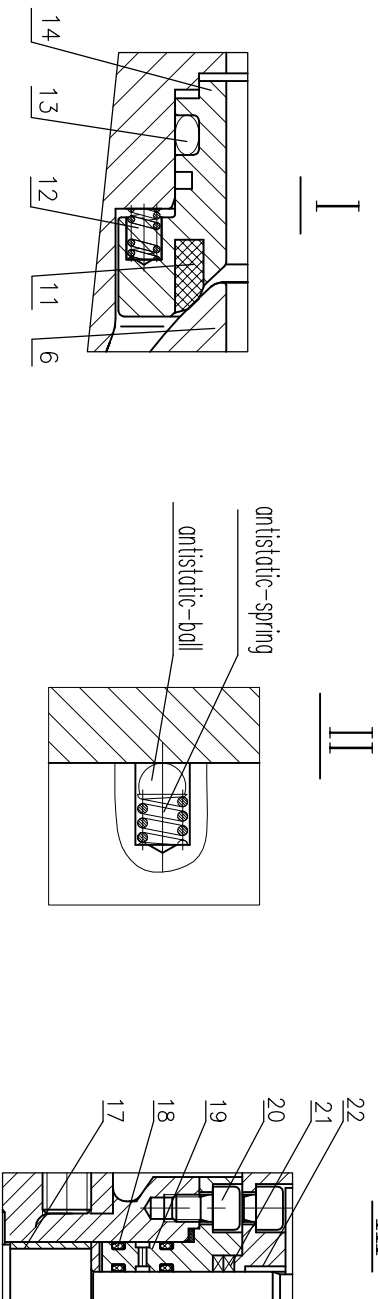

GUTTER

PROPERTY OF FBV INC., ANY UNAUTHORIZED FORM OF REPRODUCTION IS PROHIBITED

| DESIGN & MFG. | RATING | CL 150 | D | TITLE: |
|-------------------|-------------|--|-----------------------------|--|
| API 6D | CL 150 | | | NPS 6 CLASS 150 RF TRUNNION BALL VALVE GEAR OPERATED |
| PRESS-TEMP RATING | ASME B16.34 | | | |
| FACE TO FACE DIM. | ASME B16.10 | 3.0 | | |
| END CONNECTION | RF | SEAT AIR Model 4.50 BACKSEAT Model 3.14 | A B | |
| END DIMENSION | ASME B16.5 | 0.6 | | |
| PRESSURE TEST | API 6D | TEMPERATURE Model 87 | DESIGN: BILL REVIEW: BIN | DWG NO. 06BAR3C4.10R1G QUOTE NO. F00113Q170915-002617 PO NO. SPA-125 |
| MARKING | API 6D | -29 TO 120 °C -20 TO 248 °F | DATE: 04/04/2018 | |
| OTHER REQ. | API 607 | MEDIUM Water, Oil, Gas | DATE: 04/04/2018 | |

ITEM: 2

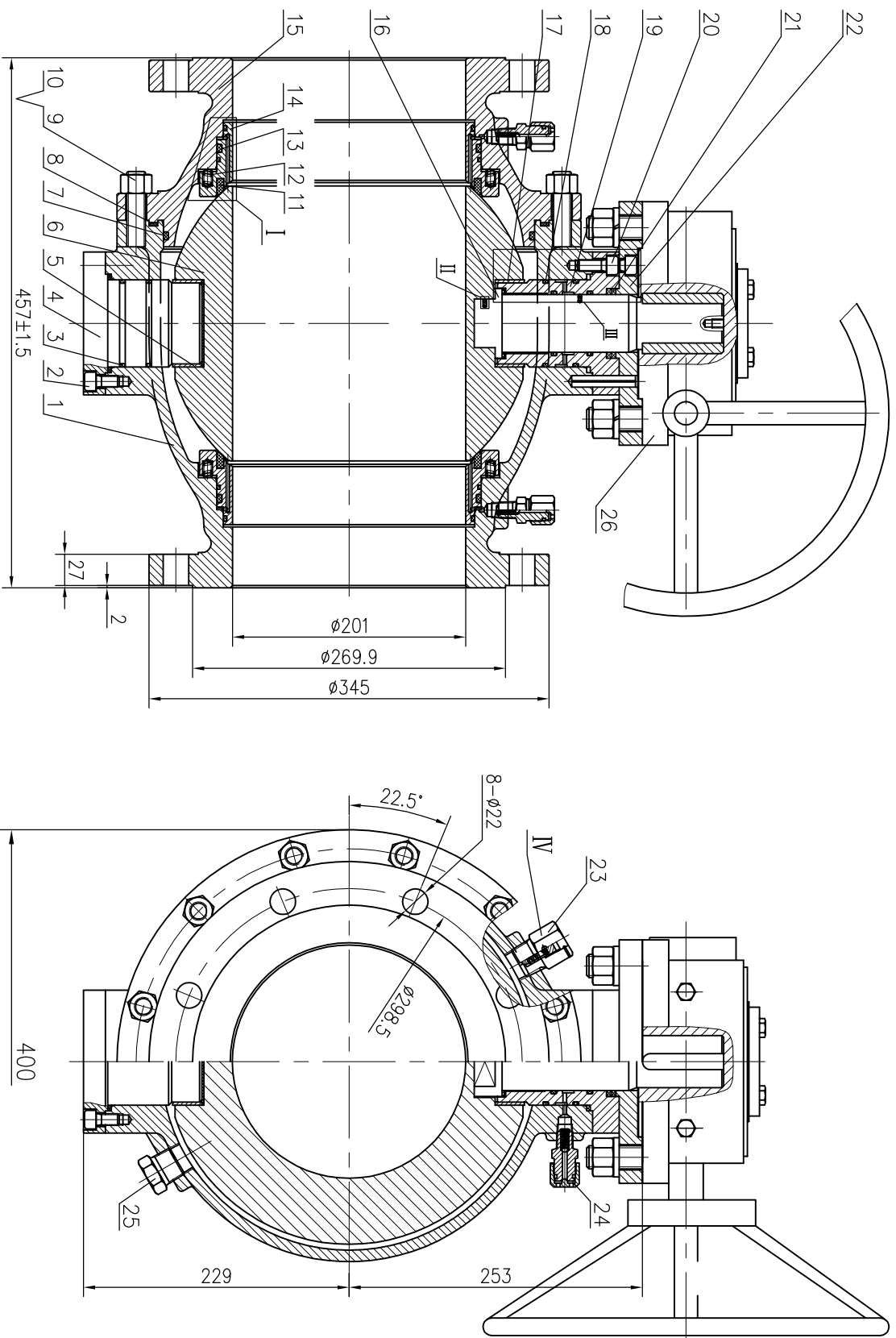

| NO. | PART NAME | MATERIAL | NOTE |
|-----|-----------------|----------------------|------|
| 1 | BODY | ASTM A216 WCB | |
| 2 | SCREW | ASTM A193 B7 | |
| 3 | O-RING | VITON | |
| 4 | TRUNNION | ASTM A105+ENP | |
| 5 | BUSHING | SS+PTFE | |
| 6 | BALL | ASTM A182 F316 | |
| 7 | O-RING | VITON | |
| 8 | GASKET | SS+FLEXIBLE GRAPHITE | |
| 9 | BOLT | ASTM A193 B7 | |
| 10 | NUT | ASTM A194 2H | |
| 11 | SEAT INSERT | RPTEF | |
| 12 | SEAT SPRING | INCONEL X750 | |
| 13 | O-RING | VITON | |
| 14 | SEAT RING | ASTM A182 F316 | |
| 15 | CLOSURE | ASTM A216 WCB | |
| 16 | STEM | ASTM A182 F316 | |
| 17 | BUSHING | SS+PTFE | |
| 18 | O-RING | VITON | |
| 19 | STUFFING BOX | ASTM A105+ENP | |
| 20 | SCREW | ASTM A193 B7 | |
| 21 | PACKING | FLEXIBLE GRAPHITE | |
| 22 | MOUNTING FLANGE | ASTM A105 | |
| 23 | VENT VALVE | SS304 | |
| 24 | GREASE FITTING | SS304 | |
| 25 | DRAIN PLUG | SS304 | |
| 26 | GEAR | ASSEMBLY | |
| 27 | | | |
| 28 | | | |
| 29 | | | |
| 30 | | | |

PROPERTY OF FBV INC., ANY UNAUTHORIZED FORM OF REPRODUCTION IS PROHIBITED

GUTTER

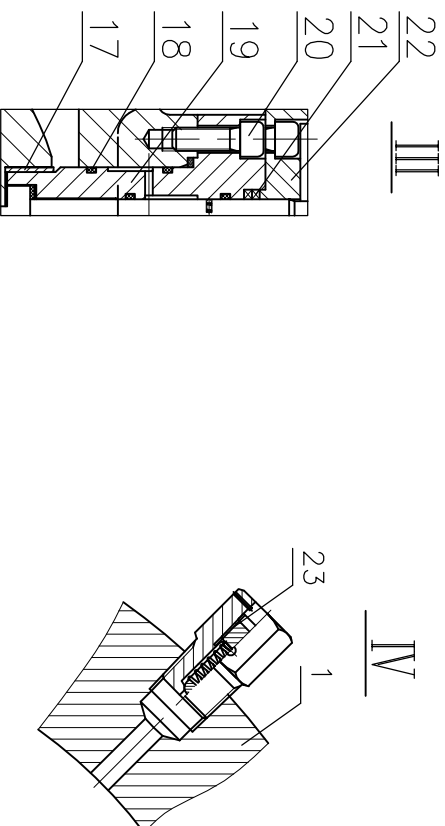
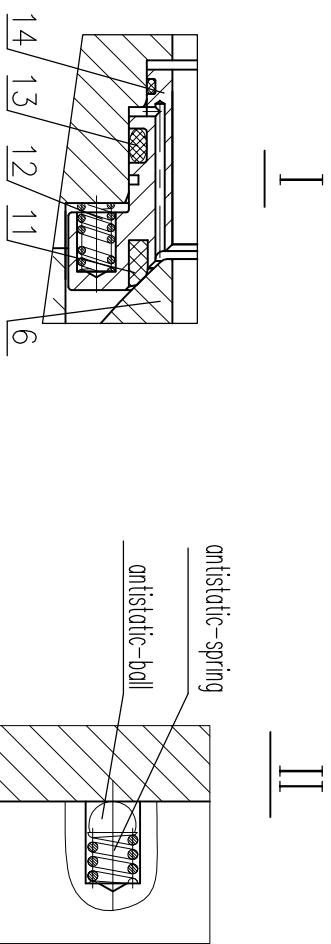

| | | | | | | | | | | | |
|--------------------------|-------------|--------------------|------------|-----------------|-----|--------------------|--|------------------|----------------------|---------------|---------|
| DESIGN & MFG. | API 6D | RATING | CL 150 | D | - | TITLE: | NPS 8 CLASS 150 RF TRUNNION BALL VALVE GEAR OPERATED | | | | |
| PRESS-TEMP RATING | ASME B16.34 | SHELL | 450 | C | - | DWG NO. | 08BAR3C4.10R1G | QUOTE NO. | F00113Q170915-002617 | PO NO. | SPA-125 |
| FACE TO FACE DIM. | ASME B16.10 | SEAT AIR | 0.6 | B | - | DESCRIPTION | NEW ISSUE FOR APPROVAL | | | | |
| END CONNECTION | RF | BACKSEAT | 87 | A | - | DESIGN: | SHEΔWN | | | | |
| END DIMENSION | ASME B16.5 | TEMPERATURE | -29 TO 120 | REV | - | PREP. APP'D | 03/04/2018 | | | | |
| PRESSURE TEST | API 6D | MARKING | API 6D | REVIEW: | BIN | DATE: | 03/04/2018 | | | | |
| OTHER REQ. | API 607 | OTHER REQ. | API 607 | APPROVE: | - | DATE: | | | | | |



FBV, INC.
2121 BRITTMOORE RD SUITE 4000
HOUSTON, TX 77043, USA
TEL: 832-203-5459 FAX: 832-203-5461
http://www.fbvvalve.com

ITEM: 3

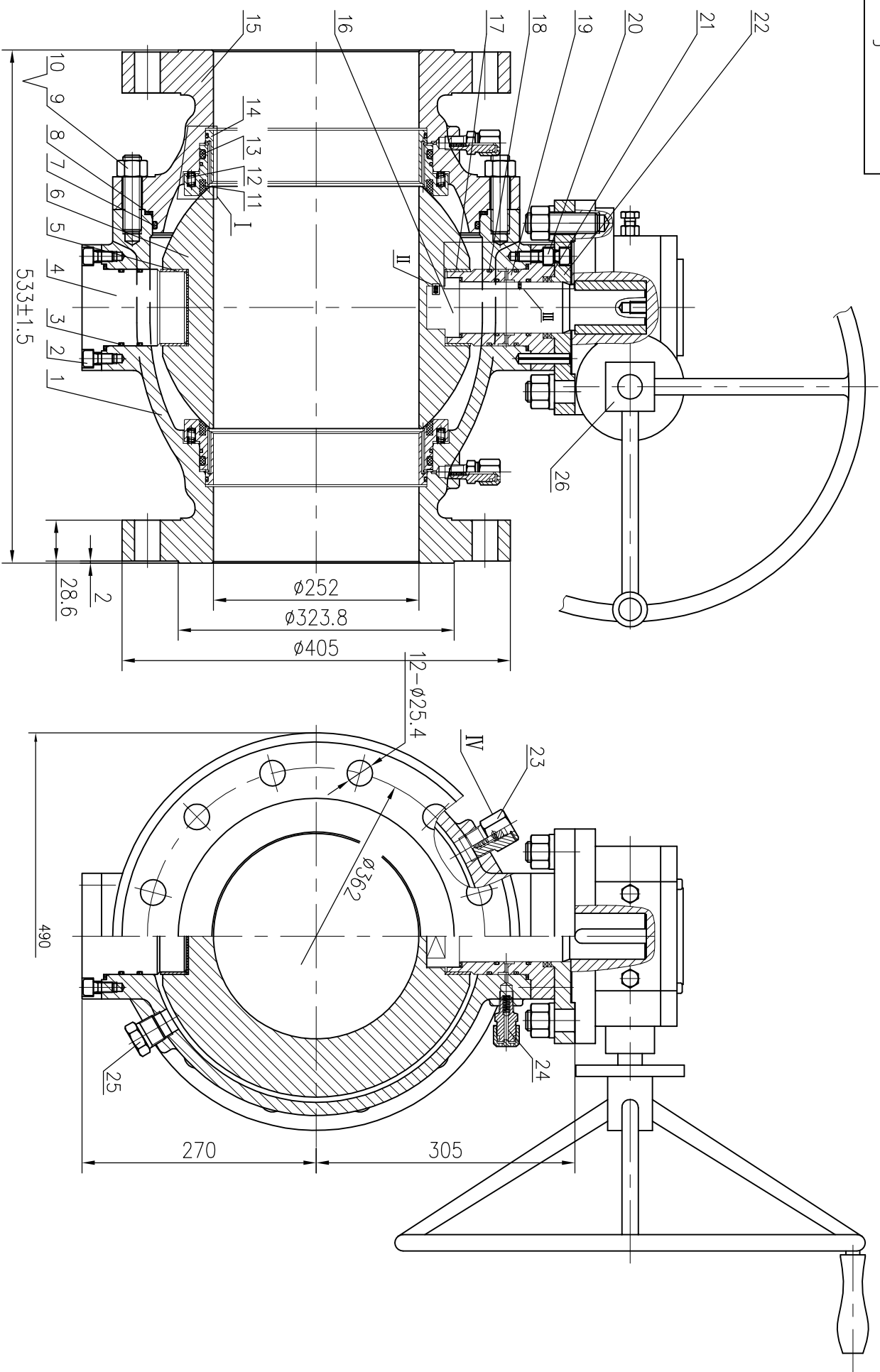

| NO. | PART NAME | MATERIAL | NOTE |
|-----|-----------------|----------------------|------|
| 1 | BODY | ASTM A216 WCB | |
| 2 | SCREW | ASTM A193 B7 | |
| 3 | O-RING | VITON | |
| 4 | TRUNNION | ASTM A105+ENP | |
| 5 | BUSHING | SS+PTFE | |
| 6 | BALL | ASTM A182 F316 | |
| 7 | O-RING | VITON | |
| 8 | GASKET | SS+FLEXIBLE GRAPHITE | |
| 9 | BOLT | ASTM A193 B7 | |
| 10 | NUT | ASTM A194 2H | |
| 11 | SEAT INSERT | RPTE | |
| 12 | SEAT SPRING | INCONEL X750 | |
| 13 | O-RING | VITON | |
| 14 | SEAT RING | ASTM A182 F316 | |
| 15 | CLOSURE | ASTM A216 WCB | |
| 16 | STEM | ASTM A182 F316 | |
| 17 | BUSHING | SS+PTFE | |
| 18 | O-RING | VITON | |
| 19 | STUFFING BOX | ASTM A105+ENP | |
| 20 | SCREW | ASTM A193 B7 | |
| 21 | PACKING | FLEXIBLE GRAPHITE | |
| 22 | MOUNTING FLANGE | ASTM A105 | |
| 23 | VENT VALVE | SS304 | |
| 24 | GREASE FITTING | SS304 | |
| 25 | DRAIN PLUG | SS304 | |
| 26 | GEAR | ASSEMBLY | |
| 27 | | | |
| 28 | | | |
| 29 | | | |
| 30 | | | |

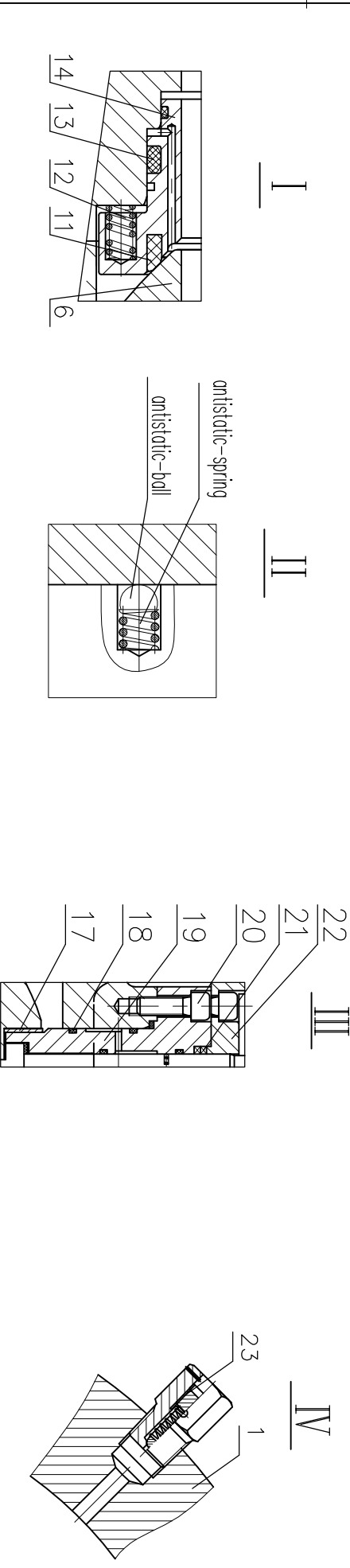

PROPERTY OF FBV INC., ANY UNAUTHORIZED FORM OF REPRODUCTION IS PROHIBITED

GUTTER

| DESIGN & MFG. | API 6D | RATING | CL 150 | DESCRIPTION | NEW ISSUE FOR APPROVAL | DATE | | TITLE: | NPS 10 CLASS 150 RF TRUNNION BALL VALVE GEAR OPERATED |
|-------------------|-------------|-------------|------------|-------------|------------------------|----------|-------|--------|---|
| PRESS-TEMP RATING | ASME B16.34 | SHELL | 450 | SEAT HDYRO | 314 | DESIGN: | SHAWN | DATE: | 03/01/2018 |
| FACE TO FACE DIM. | ASME B16.10 | SEAT AIR | 0.6 | BACKSEAT | | REVIEW: | BIN | DATE: | 03/01/2018 |
| END CONNECTION | RF | TEMPERATURE | -29 TO 120 | | | APPROVE: | | DATE: | |
| END DIMENSION | ASME B16.5 | REV | | | | | | | |
| PRESSURE TEST | API 6D | REV | | | | | | | |
| MARKING | API 6D | REV | | | | | | | |
| OTHER REQ. | API 607 | REV | | | | | | | |

DWG NO. 10BA1R3C4-10R1G **QUOTE NO.** F00113Q170915-002617 **PO NO.** SPA-125

FBV, INC.
 2121 BRITTMOORE RD SUITE 4000
 HOUSTON, TX 77043, USA
 TEL: 832-203-5459 FAX: 832-203-5461
<http://www.fbvvalve.com>

Engineered Solutions

ITEM: 4

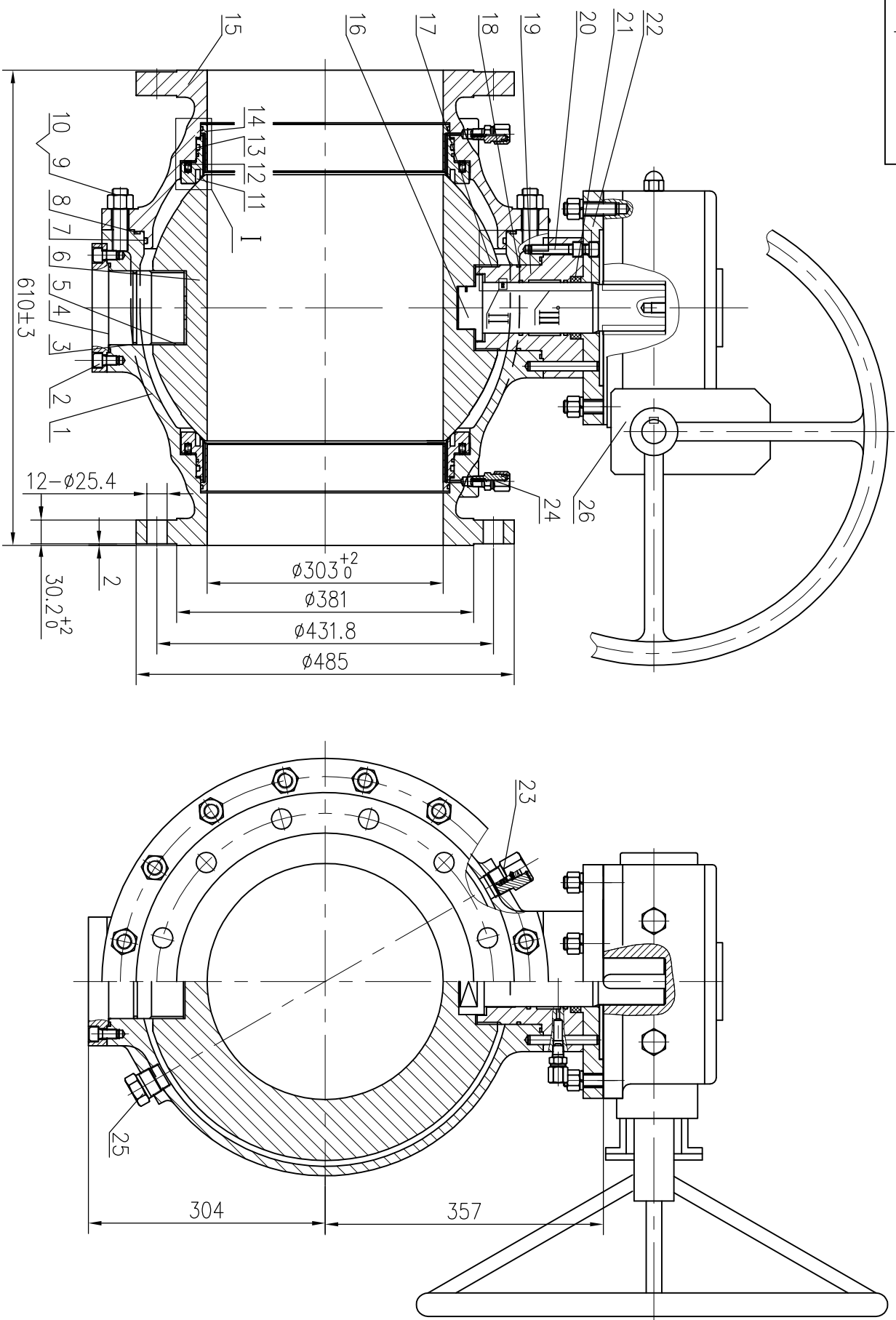

PROPERTY OF FBV INC., ANY UNAUTHORIZED FORM OF REPRODUCTION IS PROHIBITED

GUTTER

| NO. | PART NAME | MATERIAL | NOTE |
|-----|-----------------|----------------------|------|
| 1 | BODY | ASTM A216 WCB | |
| 2 | SCREW | ASTM A193 B7 | |
| 3 | O-RING | VITON | |
| 4 | TRUNNION | ASTM A105+ENP | |
| 5 | BUSHING | SS+PTFE | |
| 6 | BALL | ASTM A182 F316 | |
| 7 | O-RING | VITON | |
| 8 | GASKET | SS+FLEXIBLE GRAPHITE | |
| 9 | BOLT | ASTM A193 B7 | |
| 10 | NUT | ASTM A194 2H | |
| 11 | SEAT INSERT | RPTE | |
| 12 | SEAT SPRING | INCONEL X750 | |
| 13 | O-RING | VITON | |
| 14 | SEAT RING | ASTM A182 F316 | |
| 15 | CLOSURE | ASTM A216 WCB | |
| 16 | STEM | ASTM A182 F316 | |
| 17 | BUSHING | SS+PTFE | |
| 18 | O-RING | VITON | |
| 19 | STUFFING BOX | ASTM A105+ENP | |
| 20 | SCREW | ASTM A193 B7 | |
| 21 | PACKING | FLEXIBLE GRAPHITE | |
| 22 | MOUNTING FLANGE | ASTM A105 | |
| 23 | VENT VALVE | SS304 | |
| 24 | GREASE FITTING | SS304 | |
| 25 | DRAIN PLUG | SS304 | |
| 26 | GEAR | ASSEMBLY | |
| 27 | | | |
| 28 | | | |
| 29 | | | |
| 30 | | | |

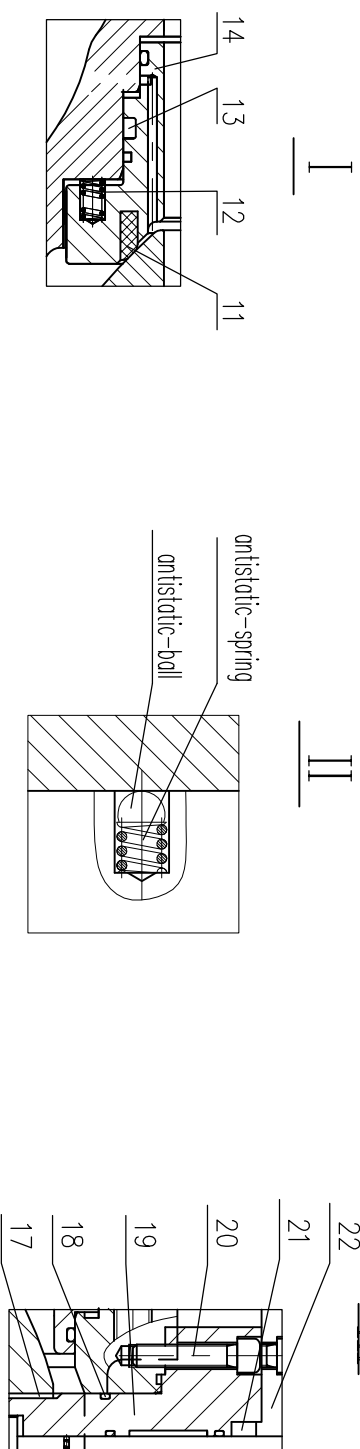

| DESIGN & MFG. | API 6D | RATING | CL 150 | D | - | TITLE: | NPS 12 CLASS 150 RF TRUNNION BALL VALVE GEAR OPERATED | | | | |
|-------------------|-------------|-------------|-------------------|-----|---|--------------------|---|-------------------|----------------------|--------|---------|
| PRESS-TEMP RATING | ASME B16.34 | SHELL | | C | - | DWG NO. | 12BAR3CL10R1G | QUOTE NO. | F00113Q170915-002617 | PO NO. | SPA 125 |
| FACE TO FACE DIM. | ASME B16.10 | SEAT AIR | 3.0 Mod. 4.50 Psl | B | - | DESCRIPTION | NEW ISSUE FOR APPROVAL | ESTIMATED TORQUE: | - | | |
| END CONNECTION | RF | BACKSEAT | 2.2 Mod. 3.14 Psl | A | - | PREP. APP'D | SHAWN SHAWN | DATE | 03/01/2016 | | |
| END DIMENSION | ASME B16.5 | TEMPERATURE | 0.6 Mod. 87 Psl | REV | - | ESTIMATED WEIGHT: | - | | | | |
| PRESSURE TEST | API 6D | | -29 TO 120 °C | | - | TAG NO./ITEM CODE: | - | | | | |
| MARKING | API 6D | | -20 TO 248 °F | | - | | | | | | |
| OTHER REQ. | API 607 | MEDIUM | Water, Oil, Gas | | - | | | | | | |

FBV, INC.
 2121 BRITTMOORE RD SUITE 4000
 HOUSTON, TX 77043, USA
 TEL: 832-203-5459 FAX: 832-203-5461
<http://www.fbvvalve.com>